

PARTS LIST

MC-PL

CONTENTS

1. MC-PL	1 ~ 2
----------------	-------

2011. 05.



P/N 523191

1. MC-PL

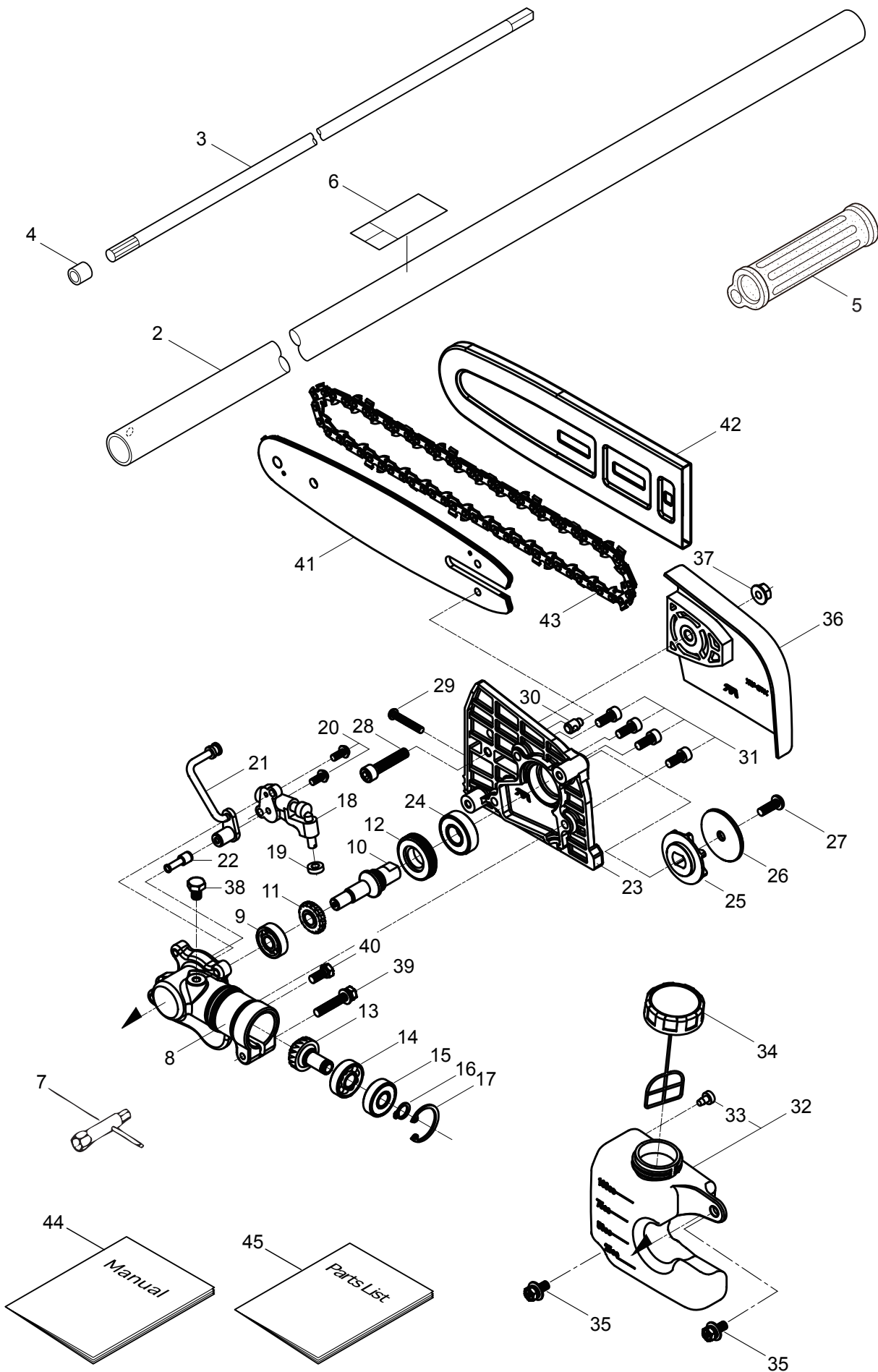

Ref. No.	Part No.	Part Name	Q'ty	Remarks
1-1	363859	MC-PL	1	
1-2	231840	Driveshaft Tube	1	
1-3	231841	Driveshaft	1	1526L
1-4	216079	Stopper	1	
1-5	215532	Shaft Grip	1	
1-6	231895	Label	1	
1-7	219968	Box Spanner	1	10x19x(-)
1-8	231855	Gearcase A	1	
1-9	227990	Bearing	1	#608
1-10	231856	Gear Shaft	1	
1-11	231857	Gear	1	
1-12	231858	Worm Wheel	1	
1-13	231859	Pinion Shaft	1	
1-14	227992	Bearing	1	#609
1-15	227993	Bearing	1	#609Z
1-16	228477	Snap Ring	1	#9
1-17	140270	Snap Ring	1	#24
1-18	231860	Oil Pump	1	
1-19	231861	Seal	1	
1-20	231862	Screw	2	
1-21	231863	Pipe, Oil	1	
1-22	231864	Strainer	1	
1-23	231865	Gearcase B	1	
1-24	227991	Bearing	1	#6001DDU
1-25	231866	Sprocket	1	
1-26	231867	Washer	1	
1-27	231868	Bolt	1	
1-28	125588	Bolt	1	M6x30
1-29	231869	Screw	1	
1-30	231870	Adjuster	1	
1-31	231871	Bolt	4	
1-32	231872	Oil Tank Ass'y	1	Incl.33
1-33	231873	Breather	1	
1-34	231874	Tank Cap Ass'y	1	
1-35	092580	Bolt	2	M5x12
1-36	231875	Chain Cover Comp.	1	
1-37	126756	Nut	1	M6
1-38	089819	Bolt	1	M6x8
1-39	261246	Cap Screw	1	M5x25
1-40	215993	Cap Screw	1	M5x10
1-41	231770	Guide Bar	1	
1-42	231771	Chain Cover	1	
1-43	231772	Chain	1	
1-44	232728	Instruction Manual	1	MC-PX,PS,PL
1-45	523191	Parts List	1	MC-PL